

ABO valve

we make processes work

TRIPLE OFFSET BUTTERFLY VALVES

Body design

Interflanged

Double flanged

Nominal size

DN80 - DN500

Working pressure

25 bar / 40 bar / 50 bar

Flange connection

PN10 / PN16 / PN25 / PN40
Class 150 / Class 300

Working temperature

-60 °C / +500 °C

Working media

Waste water
Supply water
Potable water
Hot industrial water
Crude oil / Petroleum products
Fuel / Oil / Oil derivatives
Pulp / Paper stock
Natural gas
Coke oven gas
Exhaust gas
Steam
Condensate
Air
Bitumen (Asphalt)

Tightness

Class A/B

Features

Eccentric seat design

Stellited performance
ATEX performance *)
TA-Luft stuffing box *)
SIL2/SIL3 certification *)

Double-flanged version

*) upon request

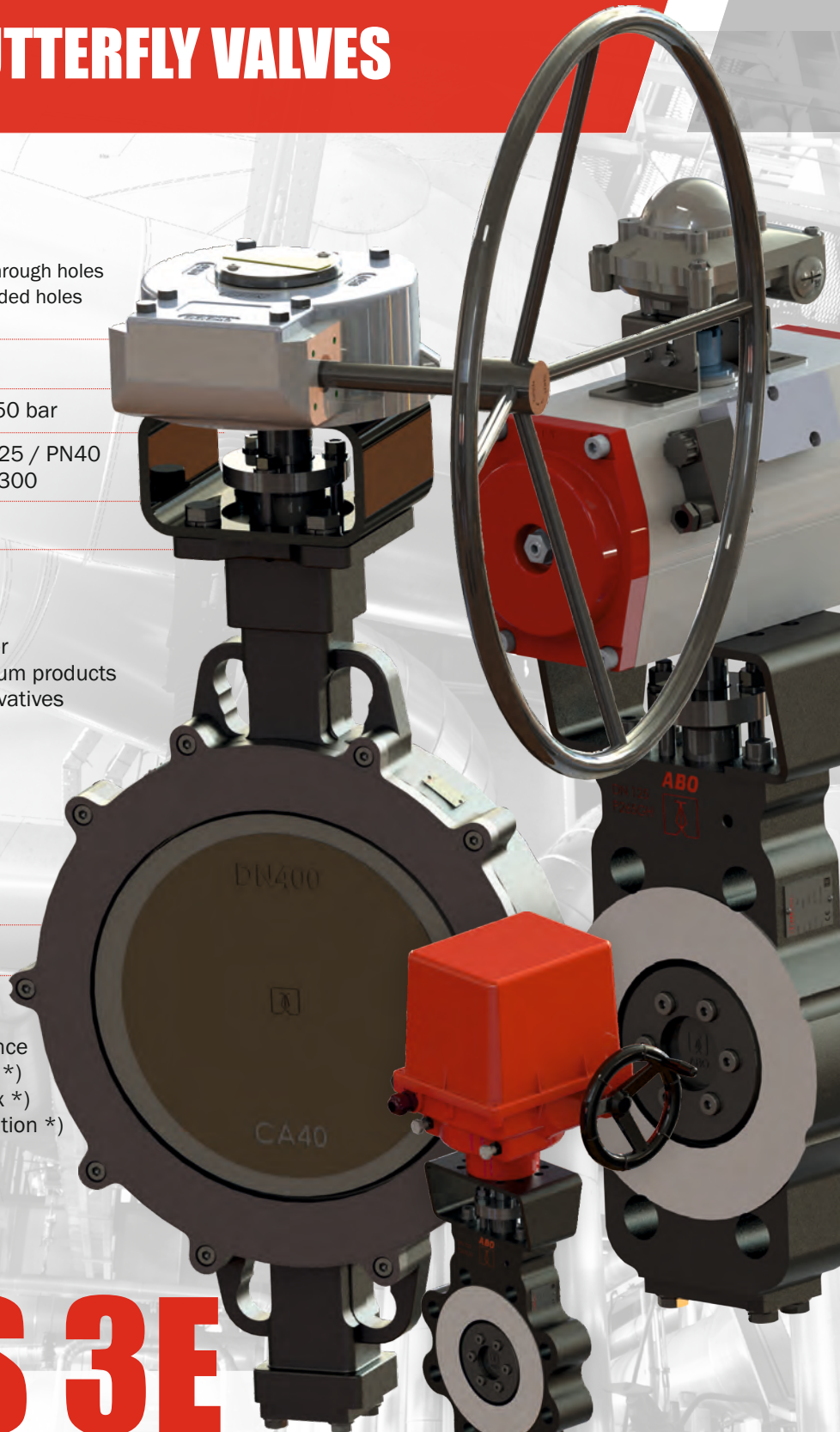

SERIES 3E

power line

www.abovalve.com

GENERAL VALVE DESCRIPTION

Czech Industrial Valve Manufacturer

The 3E-series triple offset butterfly valves are industrial fittings intended for full opening or closing flow. They may be also used for a rough flow control. They are designed for operation in very hard industrial conditions demanding safety, reliability and minimum maintenance like for example:

- power industry
- crude oil and natural gas
- refineries
- chemical and petrochemical industry
- metallurgy (and heavy industry in general)
- pulp and paper-making industry
- mining industry
- heat recovery, steam heating
- hydrocarbons processing
- fuel storage in aviation industry
- food industry

Basic properties

- triple offset disc design
- bidirectional design
- version with nitrided disc (valid for DN150 to DN500)
- stellited disc for larger sizes on the customers' demand
- used like shut-off or control fittings
- excellent tightness (tested according to international standards with high-pressure water or low-pressure air without visible leakage)
- easy operation, repairs and maintenance
- easy assembly in piping
- eccentric disc position in the body. Precise connection of the disc with the stem and pivot. Exact shaft and pivot bearing in the slide bushings.
- split sealed stem - bigger Kv
- standardized top flange according to ISO 5211 enabling mount various actuator types (electric, pneumatic, hydraulic)
- ATEX certified for explosive atmosphere
- option: TA-Luft sealed valve with special shaft gland



Type designation

3 5 L 4 B 150

- **Nominal size (DN)**
- **Body design**
B - wafer body type with through holes
T - lug body type with threaded holes
F - double-flange body type with through holes
- **Disc material**
7 - stainless steel 1.4539 (Uranus B6, AISI 904L)
4 - stainless steel 1.4408 (A351 CF8M) nitridated / stainless steel 1.4027 (Ca40) nitridated
4s - stainless steel 1.4408 (A351 CF8M) + stellite nitridated / stainless steel 1.4027 (CA40) + stellite nitridated
- **Seat material**
L - lamellar - stainless steel 1.4401 (AISI 316) + graphite / stainless steel 1.4462 + graphite
- **Body material**
7 - stainless steel 1.4539 (Uranus B6, AISI 904L)
6 - low carbon steel 1.1156 (A352 LCC) / 1.0566
6s - low carbon steel 1.1156 (A352 LCC) / 1.0566 + stellite
5 - carbon steel 1.0625 (A216 WCB) / 1.4025
5s - carbon steel 1.0625 (A216 WCB) / 1.4025 + stellite
4 - stainless steel 1.4408 (A351 CF8M) / 1.4401 (AISI 316)
4s - stainless steel 1.4408 (A351 CF8M) / 1.4401 (AISI 316) + stellite
- **Series designation**
Series 3E

Standards

Leak test	EN 12266-1, Class A/B (A: liquids, B: gas) ISO 5208, Class A/B API 598, Table 5 ANSI/FCI 70-2, Class IV
Face to face length	Interflanged design („B”/„T”) EN 558, Series 20 ISO 5752, Series 20 API 609, Category B Double flanged design EN 558, Series 13 ISO 5752, Series 13 API 609, Category B (short face-to-face length)
ATEX performance	According to 2014/34/EU Zones - 0, 1, 20, 21 Mining industry Group I, Category M1 Group II, Category 1G/2GD TX
Fire safe design	EN ISO 10497 API 607
Flange connection	EN 1092-1, 2 ASME B16.5
Top flange	EN ISO 5211
Working standard	EN 593, API 609
Marking	EN 19

VALVE MODELS

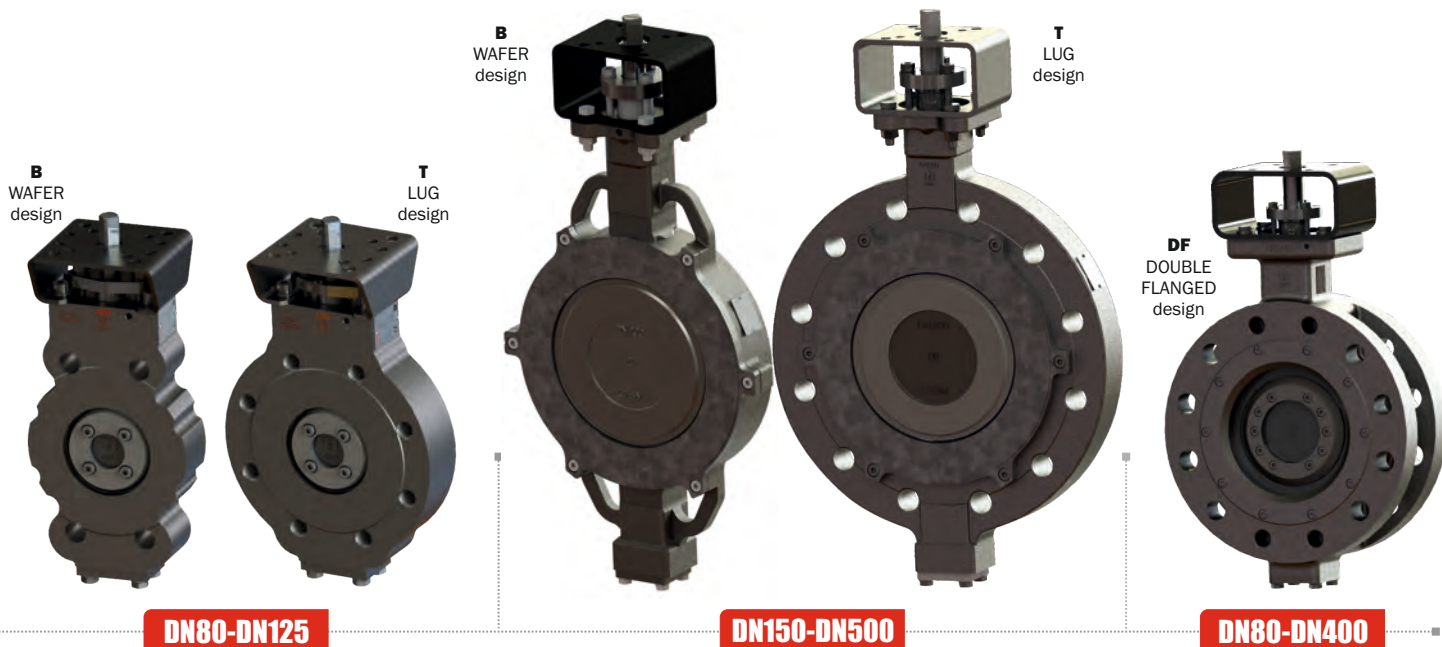

B
WAFER
design

T
LUG
design

B
WAFER
design

T
LUG
design

DF
DOUBLE
FLANGED
design

DN80-DN125

DN150-DN500

DN80-DN400

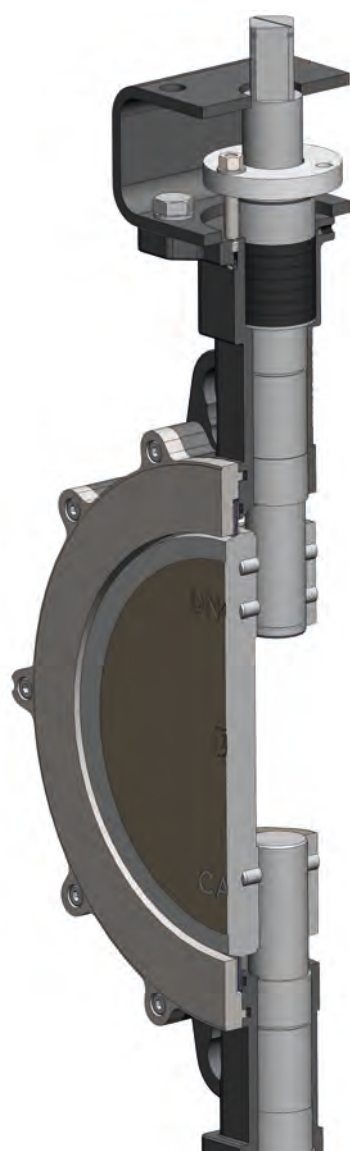

Graphite stem stuffing box

Advantages of triple offset valves

- two-piece stem (wafer/lug types DN150 to DN500)
- large flow zone
- lower pressure loss, higher Kv
- during opening and shutting the valve the **sealing ring does not rub against the seat**. They come to contact only after the valve is entirely shut.
- the seal guarantees perfect stem tightness (graphite, PTFE cord or from other material / on demand **TA-Luft** certification)
- actuator connection can be modified by means of a bracket or the stem can be extended if connected to special actuator types

Quality control

- ABO valve production facilities are certified in accordance with ISO 9001:2015 (14001, 45001)
- tightness test procedures according to standards EN 12266-1, ISO 5208, ANSI/FCI 70-2,
- production in accordance with the Pressure Equipment Directive 2014/68/EU (Module H)
- the possibility of issuing inspection certificate 3.1, 3.2
- all the actuators are adjusted and tested while assembled
- all the certificates can be downloaded at www.abovalve.com

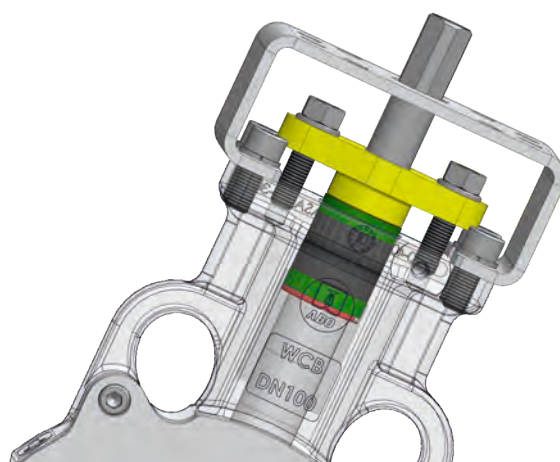

The stem seal with TA-LUFT certification for perfect tightness of pollutants into the ambient air (upon request)

DESIGN ADVANTAGES

Czech Industrial Valve Manufacturer

Triple excentricity

1. Stem axis offset off the pipeline main axis.
 2. Stem axis offset off the seal area.
 3. Seat cone axis is off the pipeline main axis.
- the triple eccentricity design contributes to very effective principle of Metal-Metal sealing, which is mainly intended for sealing high parameters of both pressures and temperatures. Properly designed geometry eliminates friction between the seating surfaces of the sealing TRIM, which helps the long lifetime of the valve. The main sealing node consists of a high-precision sealing pair with a special geometry of the offset cone.

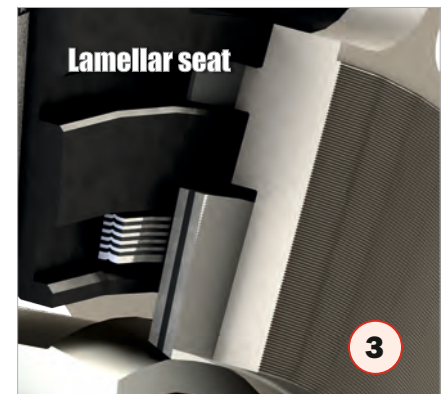
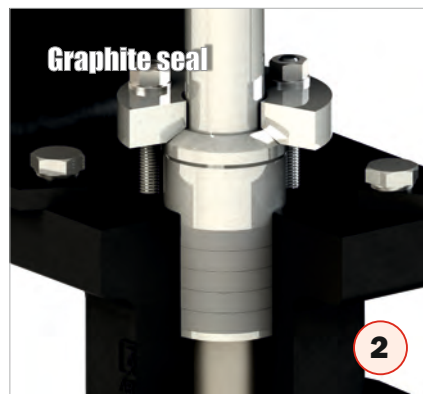
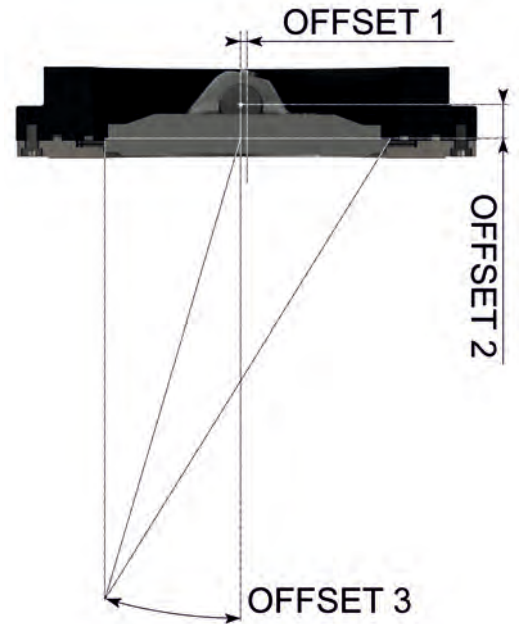

DESIGN ADVANTAGES



1. Interchangeable actuators

- standardized top flange according to ISO 5211 enables to mount manual control or actuators.
- High valve neck enables to use insulation and to provide thermal protection of handling equipment on the ISO flange (protection of actuators).

2. Graphite rings gland

- the gland system is composed from a set of graphite sealing rings preventing leaking around the stem.
- Excellent thermal resistance and very good sealing properties are the features of the material used for the gland set. Optimum pressure of the gland set is created by means of the gland flange bolts. For various media operation pressures optimal gland pressures can be generated to ensure correct function and to prevent needless control torque increase.

3. Lamellar seal

- the sealing ring is composed of stainless and graphite layers. This set is able to resist high temperatures and provides excellent resistance of the sealing element even during considerable media temperature and pressure fluctuations.

4. Split stem

- the split stem design considerably decreases pressure loss (achieving higher Kv values)

5. Spiral seal

- spiral stainless steel strap with soft graphite fill provides perfect sealing even at high fluctuations of temperature and pressure in pipeline. Excellent sealing features are guaranteed both at high and at low temperatures, i.e. while materials both stretch and shrink.

6. Abrasion elimination

- the valve is designed to minimize friction between the seat and the lamella ring. Suitable surface treatment of the parts (nitriding) contributes to that.

MATERIALS / WORKING CONDITIONS

Czech Industrial Valve Manufacturer

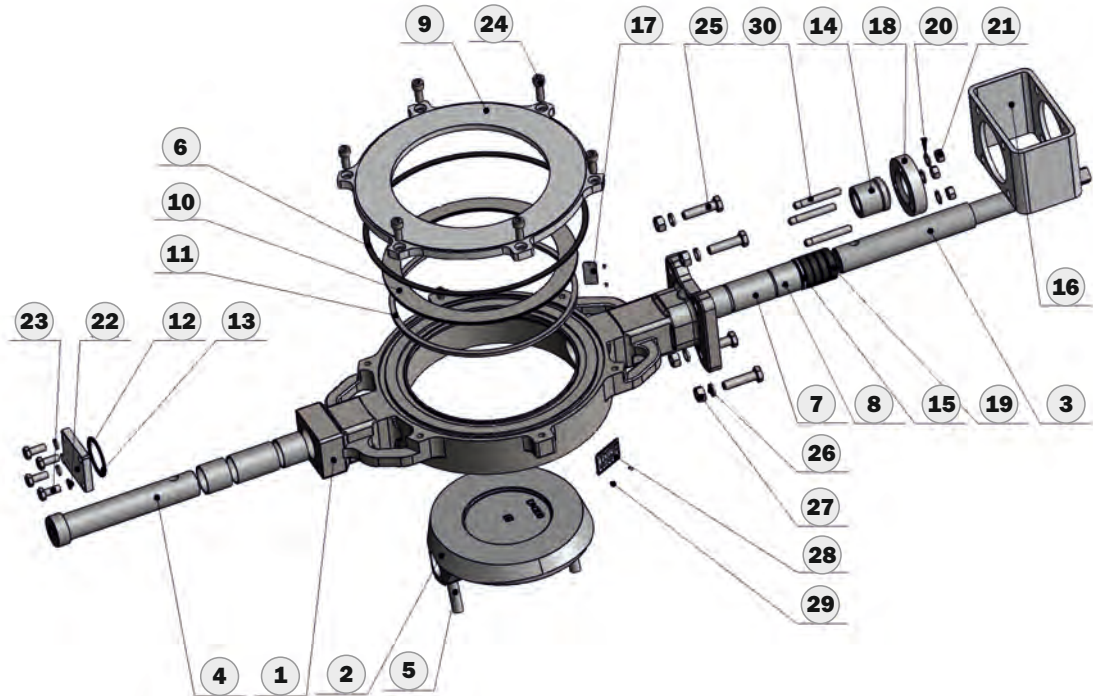

Pos.	Name	Material
1	Body **)	6 - low carbon steel 1.1156 (A352 LCC) 5 - carbon steel 1.0625 (A216 WCB) / 1.0425 4 - stainless steel 1.4408 (A351 CF8M)
2	Disc	4 - stainless steel 1.4027 (CA40) nitridated / 1.4408 (A351 CF8M) nitridated 4s - stainless steel 1.4408 (A351 CF8M) + stellite nitridated / stainless steel 1.4027 (CA40) + stellite nitridated
3	Shaft	Stainless steel 1.4021 (AISI 420) / 1.4542 (17-4PH) Duplex stainless steel 1.4462 (2205)
4	Pivot	Stainless steel 1.4021 (AISI 420) / Duplex stainless steel 1.4462 (2205)
5	Pin	Stainless steel 1.4021 (AISI 420) / Duplex stainless steel 1.4462 (2205)
6	Flange sealing	Graphite
7,8	Sleeve	Stainless steel 1.4404 (AISI 316L)
9	Flange	Carbon steel 1.0425 zinc coated / Stainless steel 1.4404 (AISI 316L)
10	Seat	Stainless steel 1.4401 (AISI 316) + graphite / 1.4462 + graphite
11	Spiral sealing	1.4542 + graphite
12	Cover	Carbon steel 1.0425 / Stainless steel 1.4404 (AISI 316)

Working pressure max.
DN80- DN125 50 bar
DN150- DN200 40 bar
DN250- DN500 25 bar

Temperature rating
Body - Carbon steel
1.0625 / 1.0425
-29 °C do 425 °C

Temperature rating
Body - Stainless steel
1.4408 / 1.4401
-60 °C do 500 °C

Coating
Black coating Celerol® Decklack
962-15, min. thickness 60-80 µm
(another coating upon request)

Pos.	Name	Material
13	Sealing	Graphite
14 *)	Packing gland	Stainless steel 1.4401 (AISI 316)
15	Washer	Stainless steel 1.4401 (AISI 316)
16	Bracket	Closed profile - 1.0576 / Bent bracket - 1.0553
17	Label	Stainless steel 1.4301
18	Gland flange	Stainless steel 1.4301
19	Gland	Graphite
20	Washer	Stainless steel A4
21	Nut	Stainless steel A4
22	Washer	Stainless steel A4
23	Bolt	Stainless steel A4
24	Bolt	Stainless steel A4
25	Bolt	Stainless steel A4
26	Washer	Stainless steel A4
27	Nut	Stainless steel A4
28	Label	Stainless steel 1.4301
29	Rivet	Stainless steel A4
30	Bolt	Stainless steel A4

Other material performance upon request. To select a suitable material performance, please contact company ABO valve. Maximum temperatures for individual seals are only permitted for specific media and short-term use.

*) for nominal size DN80-DN125 is valid:

6s - 1.0566 + stellite
5s - 1.0425 + stellite
4s - 1.4401 + stellite

***) design 4s ,5s, 6s - with stellite in the body

OPERATING TORQUES / FLANGE CONNECTION



Operating torques (Nm) vs. working pressure (bar) Opening torques

DN	80	100	125	150	200	250	300	350	400	500
NPS	3"	4"	5"	6"	8"	10"	12"	14"	16"	20"
p_{MAX} 10 bar	35	65	85	110	280	283	600	1100	1600	2490
p_{MAX} 16 bar	42	70	95	140	330	418	900	1500	2270	4100
p_{MAX} 20 bar	57	70	110	190	370	460	1030	1900	2430	5200
p_{MAX} 25 bar	70	85	130	210	490	656	1150	2500	3100	6500
p_{MAX} 30 bar	85	100	150	261	530	-	-	-	-	-
p_{MAX} 40 bar	91	125	170	350	630	-	-	-	-	-
p_{MAX} 50 bar	105	150	200	-	-	-	-	-	-	-

Operating torques are mentioned without safety factor.



Closing torques

DN	80	100	125	150	200	250	300	350	400	500
NPS	3"	4"	5"	6"	8"	10"	12"	14"	16"	20"
Closing torque (water)	84	140	175	220	450	420	400	450	500	1750
Closing torque (air)	84	140	175	220	450	565	550	1000	1300	3590
Max. shaft torque (35Lxx)	183	327	327	635	635	767	1747	2800	5078	9190
Max. shaft torque (34Lxx)	183	327	327	635	635	822	1300	2300	3800	6877

Operating torques are mentioned without safety factor.

Installation between flanges DN80 - DN500 - interflanged design

DN	80	100	125	150	200	250	300	350	400	500
NPS	3"	4"	5"	6"	8"	10"	12"	14"	16"	20"
PN10								•	•	•
PN16										
PN25										
PN40										
ANSI150										
ANSI300								x	x	•
JIS 10K					•		•	x	•	•
JIS 16K				•				•		•

For the version with threaded holes (T), please specify in the inquiry.

 standard
 • upon request
 x impossible

Coefficient KV (CV)

DN	150	200	250	300	350	400	500
NPS	6"	8"	10"	12"	14"	16"	20"
KV	1125	1950	2940	4270	5550	7870	11674
CV	1305	2262	3410	4953	6438	9129	13541

Lower nominal sizes upon request.

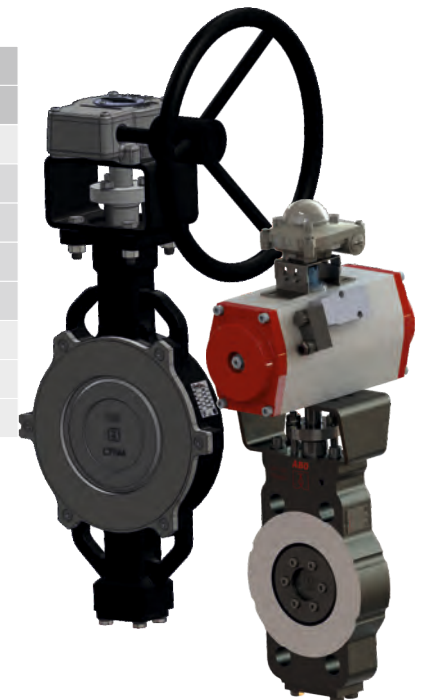

VALVE ACTUATION

Czech Industrial Valve Manufacturer

All the ABO valves can be equipped with worm drives, pneumatic and electric actuators. The upper flange according to the ISO 5211 international standard enables to directly install a manual handle or an actuator. Thus compatibility between the valve and the actuator is guaranteed.

Worm gear with handwheel

Manual gearbox housing is made from cast iron with suitable surface treatment and protection degree class IP 67. Self-locking design of the worm gear enables both to adjust basic positions open/shut and to control (throttle) media flow. The worm gearbox is simply actuated by means of a handwheel of a suitable diameter. End-limit positions of the worm gearbox are set by means of stop screws. The gearbox can be equipped with a lockable system secured by a padlock. Another way how to handle worm gearbox is using a chain. The worm gearbox as well as the hand lever can be completed with end-limit position sensors.

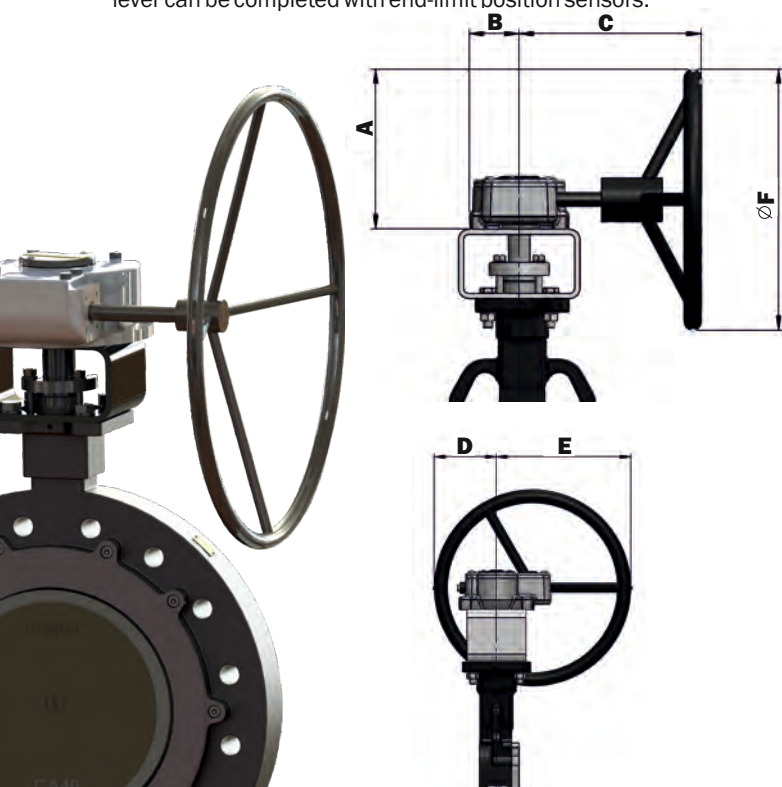

DN	A	B	C	D	E	F	Kg
80	127,5	47	138	59	140	200	2,90
100	127,5	47	138	59	140	200	2,90
125	183,5	58	209	95	205	300	5,50
150	183,5	58	209	95	205	300	5,50
200	183,5	58	209	95	205	300	5,50
250	187,5	67	240	81	219	300	7,00
300	241,5	78	265	118	281	400	9,50
350	448	110	346	295,5	504,5	800	26,0
400	455	142,5	386,5	270	530	800	38,0
500	363,3	175	429,5	175	440	500	40,0

Dimensions are mentioned in mm.
The stated weight is approximate.

Actuators

Pneumatic actuators

Pneumatic actuators ABO Series 95 can be assembled to valves in two options: single-acting or double-acting.

Electric actuators

Electric actuators ABO Series 97 are designed quarter-turn. Electric actuators can be installed on ABO valves for voltages of 24 V, 230 V or 400 V.

Special actuators types

Valves are equipped with special actuator types from major world suppliers (Auma, Regada, Valpes, etc.).

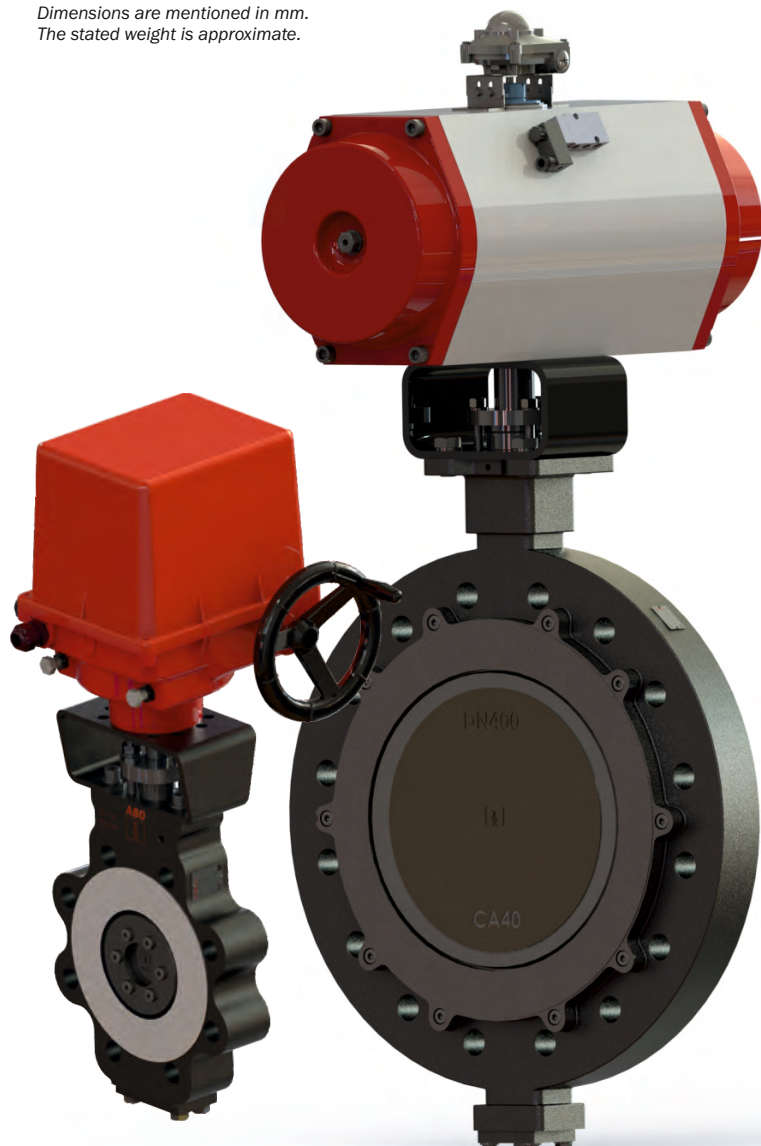

BASIC DIMENSIONS



DN80-DN125

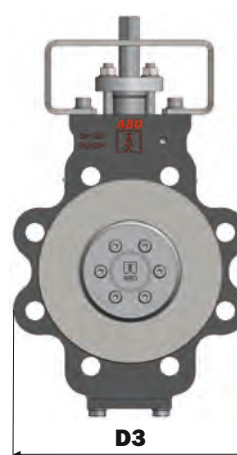
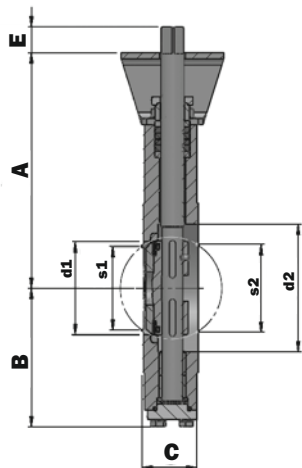

4x ϕ y/ ϕ b ISO 5211 4x ϕ y2/b2 ISO 5211

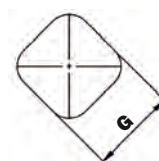
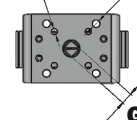

DN150-DN500

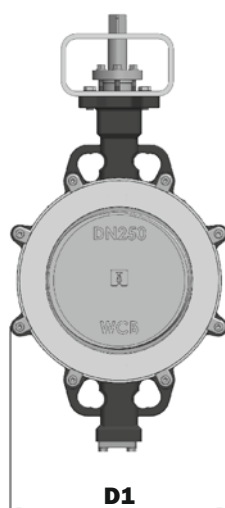
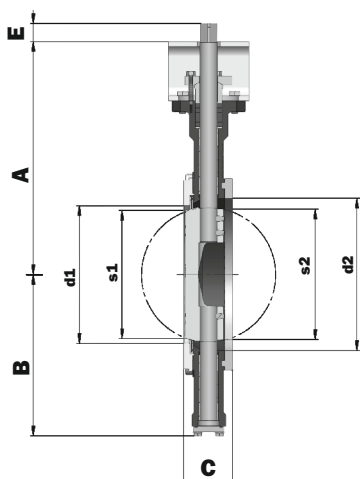

4x ϕ y/ ϕ b ISO 5211

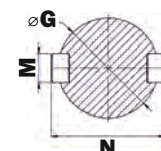
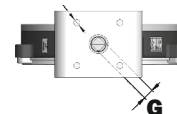

DN	d1	d2	A	B	C	D1	D3	s1	s2	E	G/M/N	ISO FLANGE	y	b	DESIGN B (kg)	DESIGN T (kg)
80	77	100	173,5	119,9	47	139,5	193	61	70,8	25	14	F07	9	70	8	15
100	90	123,5	228,5	134,4	53	163	217,6	73	83,2	25	17	F07/10	9/11	70/102	12	15
125	110	146	148	155,2	57	193	250	96	106	25	17	F07/10	9/11	70/102	17	20
150	146	155	307	213,4	57	253	318	136	143	25	17	F10	11	102	21	30
200	194	204	228,5	245,8	61	305	381	185	193	25	17	F10	11	102	28	46
250	238	259	395	274,3	69	349	450	224	236	31	22	F12	13	125	46	70
300	287	309	459,5	312,8	79	393	521	270	284	31	27	F14	17	140	67	105
350	323	342	506	354,9	92	448	577	300	308	45	27	F16	22	165	100	148
400	385	405	556	401	103	542	657	342	360	58	36	F16	22	165	131	200
500	451	502	638	431,5	127	615	730	421,5	439	110	ϕ 60 /18/68,4	F16*/F25	18/22	165/254	275	360

Dimensions are mentioned in mm, weight in kg. Additional nominal sizes upon request.
DN500, connection F16, only up to 10 bar.

PRESSURE AND TEMPERATURE CURVES

Czech Industrial Valve Manufacturer

Pressure and temperature curve
Body: carbon steel 1.0625

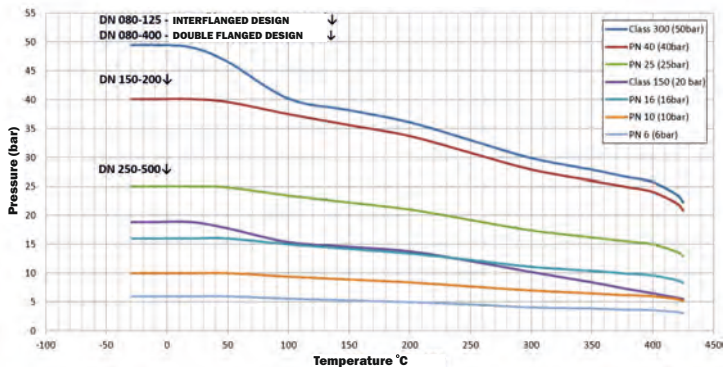

Pressure and temperature curve
Body: stainless steel 1.4408

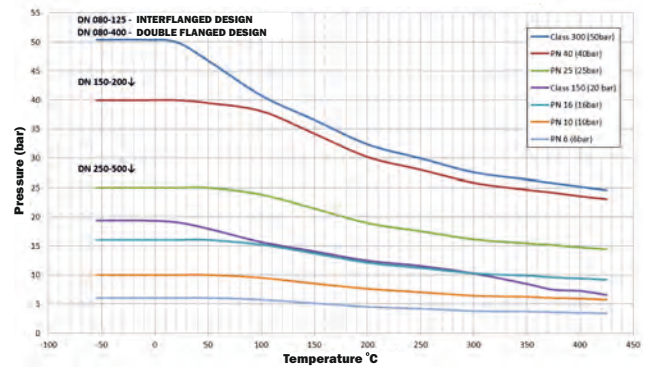

DOUBLE FLANGED DESIGN TRIPLE EXCENTRICITY

Body design

Double flanged body with through holes

Design performance

Type „F” long face-to-face dimension, Series 13 acc. to ISO 5752-13

Nominal size

Type „F” DN80 - DN400

Working pressure

50 bar

Tightness

EN 12266-1, Class A

Working temperature

body - Carbon steel 1.0625
-29 °C / +425 °C
body - Stainless steel 1.4408
-60 °C / +500 °C

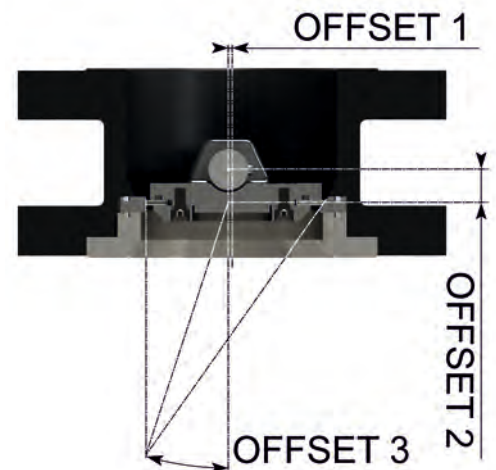

Triple eccentricity

1. Stem axis offset off the pipeline main axis.
 2. Stem axis offset off the seal area.
 3. Seat cone axis is off the pipeline main axis.
- the triple eccentricity design contributes to very effective principle of Metal-Metal sealing, which is mainly intended for sealing high parameters of both pressures and temperatures. Properly designed geometry eliminates friction between the seating surfaces of the sealing TRIM, which helps the long lifetime of the valve. The main sealing node consists of a high-precision sealing pair with a special geometry of the offset cone.

10 / ABO valve Czech

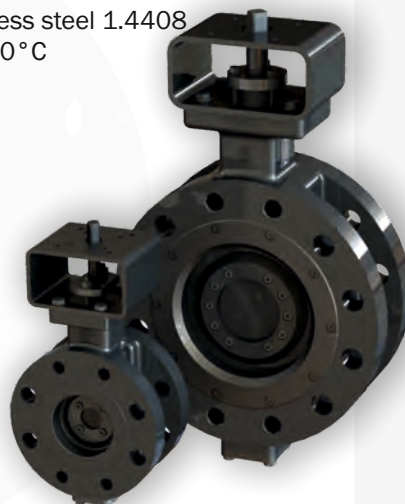

DESIGN ADVANTAGES

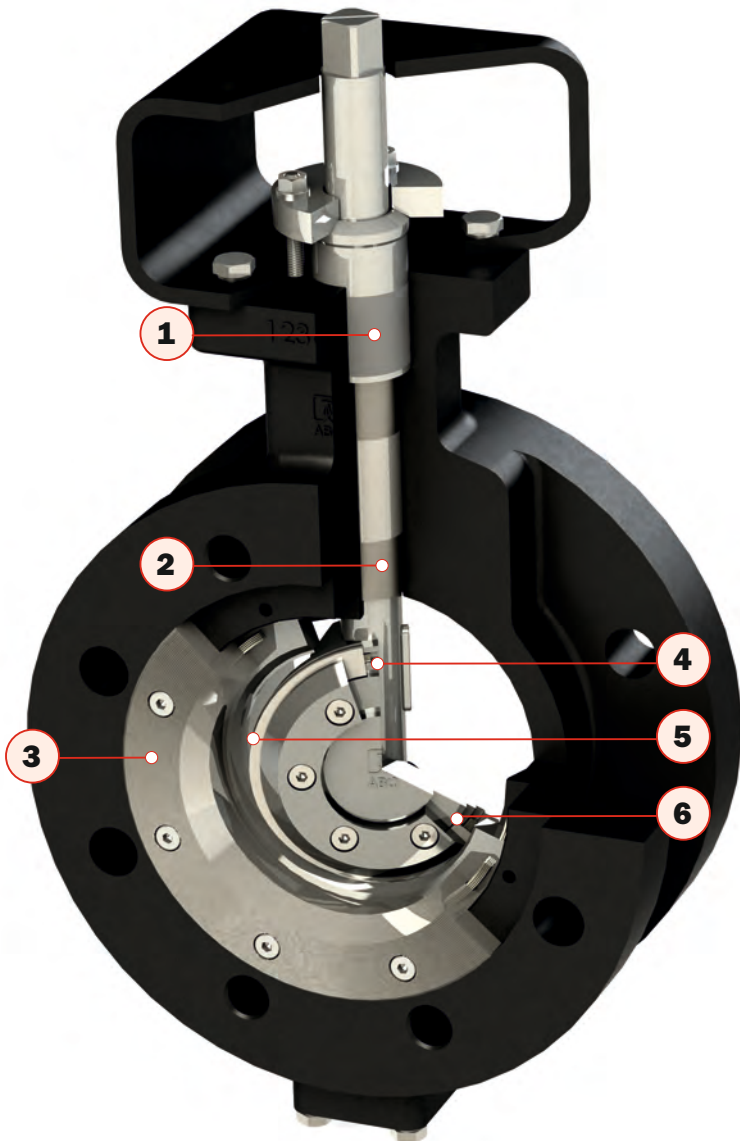

1. Interchangeable actuators

- standardized upper flange according to ISO 5211 enables to mount manual control or actuators. High valve neck enables to use insulation and to provide thermal protection of handling equipment on the ISO flange (protection of actuators).

2. Shaft bearings

- precise production of sliding bushes, including the nickel-plated surface treatment, ensures very precise guidance and position of the valve control shaft

3. Seat pressure ring

- the pressure ring ensures the correct position of the seat in the body

4. Lamellar seal

- the sealing ring ensuring the tightness of the valve itself is made of individual layers of stainless steel, which are interlaced with a graphite layer

5. Disc sealing ring

- a sealing ring combined with a spiral seal, which allows its precise setting toward to the disc and ensures a perfect tightness. Thanks to this design, the laminated sealing ring can be easily replaced at any time.

6. Replaceable seat

- exchangeable seat in the body can be made of a wide range of materials, which with their mechanical properties help to long lifespan (abrasion resistance)

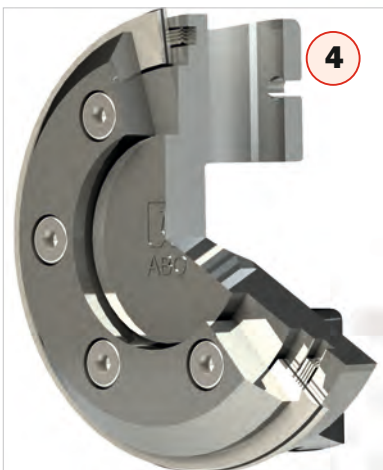

MATERIALS / WORKING CONDITIONS

Czech Industrial Valve Manufacturer

Pos.	Name	Material
1	Body	5 - carbon steel 1.0625 (A216 WCB) + protective coating 4 - stainless steel 1.4408 (A351 CF8M)
2	Disc	4 - stainless steel 1.4408 (A351 CF8M)
3	Shaft	Stainless steel I 1.4021 (AISI 420)
4	Sealing ring	Lamellar - stainless steel 1.4401 (AISI 316) + graphite 98%
5	Disc flange	Stainless steel 1.4301 (A351 CF8)
6	Spiral sealing	Stainless steel 1.4541 + graphite
7	Cover	Steel 1.0553
8	Cover sealing	Stainless steel 1.4541 + graphite
9	Stopper	Stainless steel 1.4401 (AISI 316)
10	Distance ring	Stainless steel 1.4404
11	Seal	Graphite
12	Washer	Stainless steel 1.4404
13	Gland casing	Stainless steel 1.4401 (AISI 316)
14	Sealing flange	Stainless steel 1.4301
15	Bracket	Stainless steel 1.0576
16	Seat	Stainless steel 1.4462
17	Pressure ring	Stainless steel 1.4462 + Zinc
18	Spiral sealing	Stainless steel 1.4541 + graphite
19	Sleeve	Stainless steel 1.4404
20	Sleeve	Stainless steel 1.4404 (316L) + Nickel
21	Split sleeve	Stainless steel 1.4404 (316L)
22	Stud bolt	Stainless steel A4
23	Washer	Stainless steel A4
24	Nut	Stainless steel
25	Washer	Stainless steel A4
26	Bolt	Stainless steel A4
27	Bolt	Stainless steel A4
28	Set screw	Stainless steel A2
29	Spring	Stainless steel A4
30	Bolt	Stainless steel A4
31	Wedge lock washer	Stainless steel A4
32	Bolt	Stainless steel A4
33	Washer	Stainless steel A4
34	Bolt	Stainless steel A4
35	Label Delta P	Stainless steel 1.4301 (304)
36	Label	Stainless steel 1.4301 (304)
36	Grooved stud	Steel

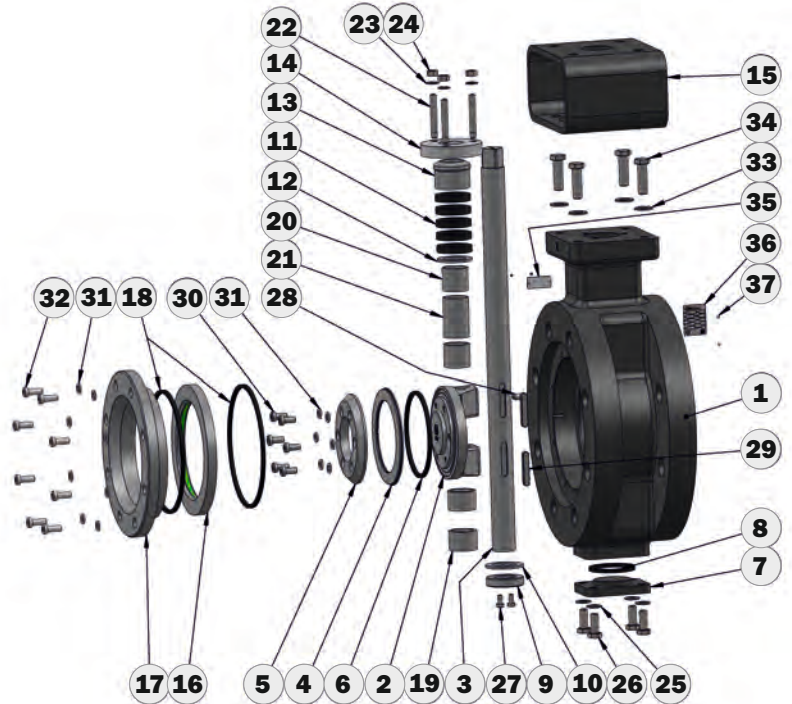

Installation between flanges DN80 - DN400

DN	80	100	125	150	200	250	300	350	400
NPS	3"	4"	5"	6"	8"	10"	12"	14"	16"
PN10									
PN16									
PN25									
PN40									
ANSI150									
ANSI300									
JIS 10K					•		•	×	×
JIS 16K				•					

standard • upon request × impossible

Working pressure max.
DN80- DN400 50 bar

Temperature rating
Body - Stainless steel 1.4408
-60 °C do 500 °C

Temperature rating
Body - Carbon steel 1.0625
-29 °C do 425 °C

Coating
Black coating Celerol® Decklack
962-15, min. thickness 60-80 µm
(another coating upon request)

VALVE ACTUATION / TECHNICAL INFORMATION



All the ABO valves can be equipped with worm drives, pneumatic and electric actuators. The upper flange according to the ISO 5211 international standard enables to directly install a manual handle or an actuator. Thus compatibility between the valve and the actuator is guaranteed.

Worm gear with handwheel

Manual gearbox housing is made from cast iron with suitable surface treatment and protection degree class IP 67. Self-locking design of the worm gear enables both to adjust basic positions open/shut and to control (throttle) media flow. The worm gearbox is simply actuated by means of a handwheel of a suitable diameter. End-limit positions of the worm gearbox are set by means of stop screws. The gearbox can be equipped with a lockable system secured by a padlock. Another way how to handle worm gearbox is using a chain. The worm gearbox as well as the hand lever can be completed with end-limit position sensors.

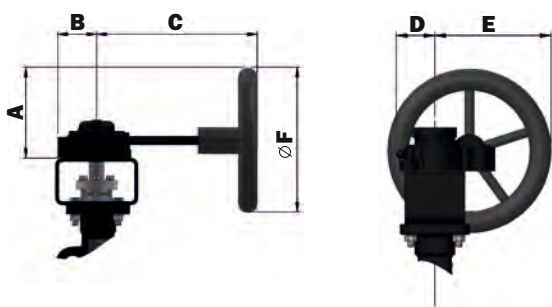

DN	A	B	C	D	E	F	Kg
80	127,5	47	138	47,5	140	200	2,90
100	127,5	47	138	47,5	140	200	2,90
125	183,5	58	209	62	202,5	300	5,50
150	183,5	58	209	62	202,5	300	5,50
200	183,5	58	209	62	202,5	300	5,50
250	392	100	305	100	436	700	17
300	398	110	346	110	454,5	700	25
350	505	142,5	397	142,5	580	900	37,5
400	511,5	146,5	422	142	590	900	49,5

Dimensions are mentioned in mm.
The stated weight is approximate.

Actuators

Pneumatic actuators ABO Series 95 can be assembled to valves in two options: single-acting or double-acting. **Electric actuators ABO Series 97** are designed quarter-turn. Electric actuators can be installed on ABO valves for voltages of 24 V, 230 V or 400 V. Valves can be equipped with **special actuator types** from major world suppliers (Auma, Regada, Valpes, etc.).

Operating torques (Nm) vs. working pressure (bar)

DN	80	100	125	150	200	250	300	350	400
NPS	3"	4"	5"	6"	8"	10"	12"	14"	16"
p_{MAX} 6 bar	28	65	45	120	315	502	789	1195	1687
p_{MAX} 10 bar	35	65	45	140	345	585	875	1370	1810
p_{MAX} 16 bar	42	70	60	160	451	787	1098	1469	2355
p_{MAX} 25 bar	70	85	85	220	520	876	1314	1963	2927
p_{MAX} 40 bar	91	125	120	400	713	1251	1918	1689	4310
p_{MAX} 50 bar	105	150	140	400	960	1720	2630	3870	5800

Operating torques are mentioned without safety factor.

Closing torques

DN	80	100	125	150	200	250	300	350	400
NPS	3"	4"	5"	6"	8"	10"	12"	14"	16"
Closing torque (water)	84	140	175	400	650	950	1300	2640	4160
Closing torque (air)	84	140	175	400	650	950	1300	2640	4160
Max. shaft torque (35Lxx)	183	327	327	635	1182	2184	3367	7086	11412
Max. shaft torque (34Lxx)	183	327	327	476	1182	2184	3367	7086	11412

Operating torques are mentioned without safety factor.



NOTES

A large grid of graph paper for taking notes, consisting of 20 columns and 30 rows of small squares.

BASIC DIMENSIONS

Czech Industrial Valve Manufacturer

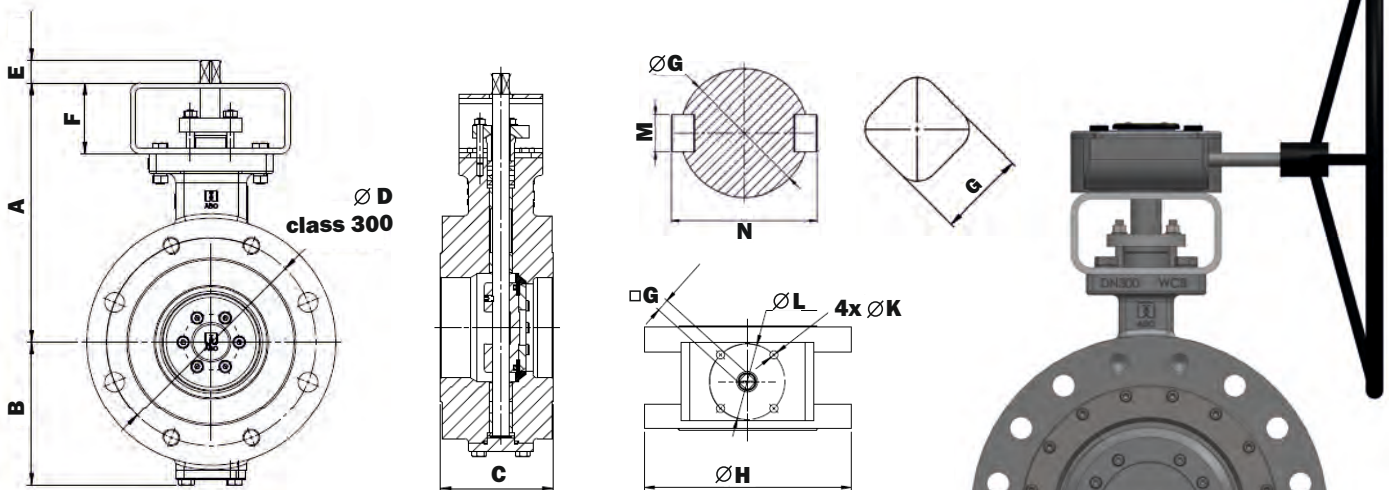

DN	A	B	C	D	E	F	G/M/N	Ø H	K	L	ISO FLANGE	Weight (kg)
80	240	126	114	168,1	25	80	14	209,6	11	102	F07	24
100	272	149	127	200	25	80	17	254	11	102	F07/10	36
125	292	161,9	140	235	25	80	17	279,4	11	102	F07/10	46
150	292	194,4	140	235	24	100	22	318	13	125	F07/10	63
200	380	229,5	152	330,2	24	100	22	380	13	125	F12	90,5
250	440	256	165	387,4	31	120	27	445	17	140	F14	127
300	470	300	178	450,8	39	120	36	521	22	165	F16	172,5
350	515	335,5	190	514,4	80	120	ø55 /16/62,6	585	22	165	F16	255
400	604	381,5	216	571,5	100	150	ø64 /18/72,4	660	18 (8x)	254	25	345

Dimensions are mentioned in mm.

Czech Republic

ABO valve, s.r.o.
Dalimilova 285/54
783 35 Olomouc
tel.: +420 585 224 087
sales@abovalve.com

Slovak Republic

ABO Slovakia, s.r.o.
Banská Bystrica
tel.: +421 484 145 633
sales.sk@abovalve.com

Germany

ABO Armaturen GmbH
Essen
tel.: +49 (0)152 262 29501
sales.de@abovalve.com

Russia

ABO Armatura LLC
Smolensk
tel.: +7 (4812) 240 020
sales.ru@abovalve.com

Ukraine

ABO Ukraine LLC
Dnipro
tel.: +38 056 733 95 70
sales.ua@abovalve.com

Turkey

ABO Armaturen LTD STI
Istanbul
tel.: +90 216 527 36 34
sales.tr@abovalve.com

China

ABO Flow Control
Shanghai
tel.: +86 136 01 522 831
sales.cn@abovalve.com

India

ABO Controls Pvt. Ltd.
Mumbai
tel.: +91 99 2002 9994
sales.in@abovalve.com

Singapore

ABO Valve Pte. Ltd.
Singapore
tel.: +65 9169 4562
sales.sg@abovalve.com

United Arab Emirates

Sales representation
Abu Dhabi
tel.: +971 56 9207964
bharti@abovalve.com

Bahrain

Sales representation
Manama
tel.: +973 3444 9065
jimnichen@abovalve.com

Valid since: 09/2021



Follow us on:



www.abovalve.com



The technical information described in this leaflet is tentative and for general use only and does not constitute a recommendation or guarantee for any specific service or application requirement. Please consult ABO representative or factory for specific requirements and material selection for your intended application. The right to change or modify product design or product without prior notice is reserved. ABO valve accepts no liability for damages caused by bad interpretation or use of the information included in this brochure.